

VESTA® Mixed Matched Sterile Valves



Pure valve technology by GEA Tuchenhagen

Process Equipment

GEA Tuchenhagen

VESTA® Type HCA mixed matched sterile valves

The VESTA® type HCA mixed matched sterile valve is a further development of the VESTA® type C basic variant. The mixed matched type HCA is used wherever different types of connections are required in the through-flow line and the branch line. It is designed to be used as an extraction valve for pipework systems, or for distribution of media.



Shut-off takes place in the immediate vicinity of the through-flow line. This makes reliable cleaning possible. VESTA® type HCA mixed matched sterile valves allow the integration of large nominal pipework diameters with the extraction of small quantities in a trouble-free and cost-effective manner. Moreover the improved flow paths, as well as the integration of additional sterilisation connections, reduce the dead pockets. The significantly reduced pipeline volume on the extraction side and the improved selfdraining are further advantages compared with conventional solutions.

Type HCA mixed matched sterile valves - a further variant within the VESTA® sterile valve programme - are available in the following diameters:

DIN-Series	DN 15 to DN 100 (through-flow line) - DN 10 to DN 32 (branch line)
ISO-Series	ISO 17.2 to 114.3 (through-flow line) - ISO 13.5 to ISO 33.7 (branch line)
OD-Series	0,75" OD to 4" OD (through-flow line) - 0,5" OD to 1" OD (branch line)

Further mixed matched sizes on request.

Body configurations:

Nominal diameters to DN 50 / ISO 60.3 / 2"OD (through-flow line) – single piece from solid material

Nominal diameters from DN 65 / ISO 76.1 / 2.5" OD (through-flow line) – welded construction with necked T-piece

The well-known GEA Tuchenhausen service facilities are always available to answer questions and provide technical assistance.

VESTA® Type HCA mixed matched sterile valves

VESTA® type HCA mixed matched sterile valves are designed with almost no doming, can be introduced in all installation orientations and allow optimal cleaning.

Type HCA mixed matched sterile valves make possible the implementation of neat procedural solutions in your plant designs.

The design features

- Block body, single piece, manufactured from solid material, (\leq DN 50 / ISO 60.3 / 2" OD in the through-flow line)
- PTFE bellows as shut-off element for universal applications
- Hermetic sealing of the valve interior space from the external environment by means of patented bellows sealing system
- Compact design
- Self-locking groove nut connection

The advantages

- Pocket-free design with minimal doming
- Self-draining
- Reliable CIP/SIP cleaning by means of flow-optimised design
- Long service life for the PTFE bellows
- Use of standard VESTA® pneumatically and manually driven valve inserts
- Sealing approximately in the plane of the pipework
- Easy and safe maintenance



VESTA® type HCA mixed matched sterile valves, DN 50 / 25

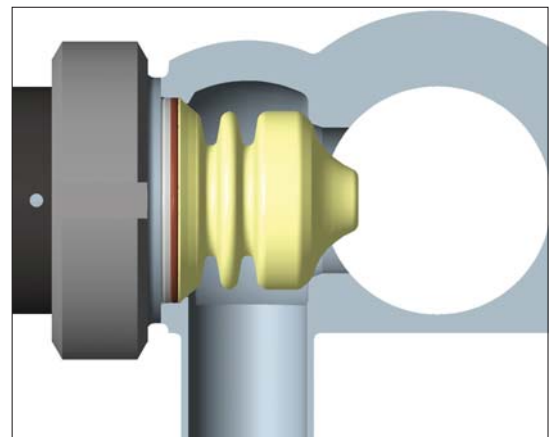

Closed valve setting

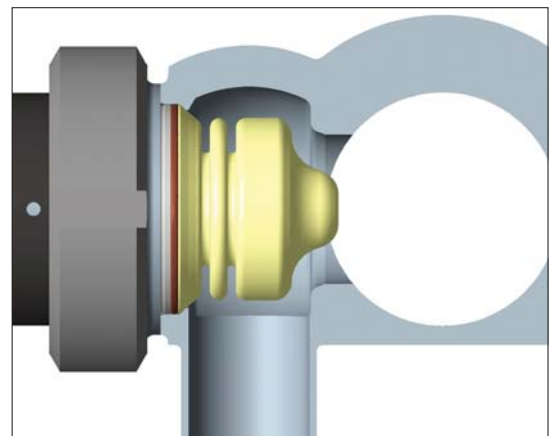

Open valve setting

VESTA® Type HCA mixed matched sterile valves

Field of application	Suitable for the control and regulation of all types of fluid and gaseous media	
	Operating pressure	max 6 bar
	Control air pressure	NC actuator - min. 5 bar, max. 10 bar NO actuator - min. 5 bar, max. 6 bar
	Operating temperature	-10 °C to max 135 °C
	Sterilisation temperature	max 150 °C.
Installation orientation	Preferably horizontal (through-flow line), drive vertical or horizontal	
Materials		
<i>In contact with product</i>	body	1.4435 / AISI 316L
	PTFE-bellows	TFM 1705, FDA-conformity
<i>Not in contact with product</i>	synthetic actuator	polyphenylene sulphide (PPS)
	stainless steel actuator	1.4301/ AISI 304
Surfaces		
<i>Internal</i>	Ra ≤ 0.8 µm (standard) Ra ≤ 0.4 µm, (as option)	
<i>External</i>	bright metal (body and stainless steel drives) Synthetic actuator - surface structure in accordance with VDI 3400, roughness level 30	
Nominal diameters	DIN - DN 10 up to DN 100 external diameter in accordance with DIN 11850 Series 2 / DIN 11866, Series A ISO - ISO 13.5 up to ISO 114.3 External diameter in accordance with DIN EN ISO 1127 / DIN 11866, Series B OD - 0.5" OD up to 4" OD External diameter in accordance with ASME BPE / DIN 11866, Series C	
Step-down ratios	DN 15 up to DN 100 (through-flow line) - DN 10 up to DN 32 (branch line) ISO 17.2 up to ISO 114.3 (through-flow line) - ISO 13.5 up to ISO 33.7 (branch line) 0.5" OD up to 4" OD (through-flow line) - OD 0.5" OD up to 1" OD (branch line)	
Drive variants	Manual actuator in plastic Pneumatic actuator in plastic Pneumatic actuator in stainless steel	
Certifications	Documented evidence of the following quality features - housing body with material inspection certificate in accordance with EN 10204/3.1 (on request) - documented evidence of the surface roughness in the form of a test report in accordance with EN 10204 (on request to 3.1) - documented evidence of the delta ferrite content in the form of a test report in accordance with EN 10204, optional (on request) - documented evidence for the PTFE bellows in the form of a test report in accordance with EN 10204 FDA certificate of conformity– FDA 21 § 177.1550 (on request to 3.1) - certificate for PTFE bellows (TFM 1705) concerning the documented evidence of biocompatibility in accordance with USP Class VI (on request)	

