

**GEA Tuchenhagen GmbH**  
 Am Industriepark 2-4  
 D-21514 Büchen  
 Tel: +49/4155/49-0  
 Fax: +49/4155/49-2428  
 email: info@tuchenhagen.com  
[www.tuchenhagen.de](http://www.tuchenhagen.de)

# Cleaner Checklist



GEA Tuchenhagen

1	<b>Company/Cust.No:</b>	
	<b>Contact:</b>	
	<b>Phone:</b>	
	<b>Fax:</b>	
	<b>email:</b>	

2	<b>Project / Tag No:</b>	
---	--------------------------	--

3	<b>Current Status</b>	What is the current method of cleaning:	
		cleaning fluid:	estimated cleaning time:
		max. ambient temperature:	max. medium temperature:
		Competition	

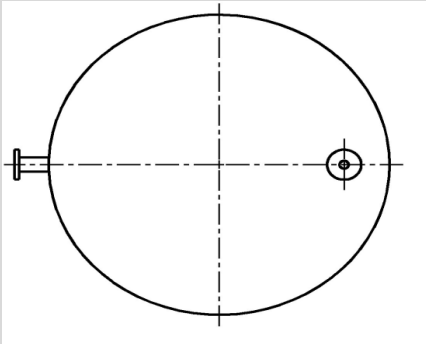
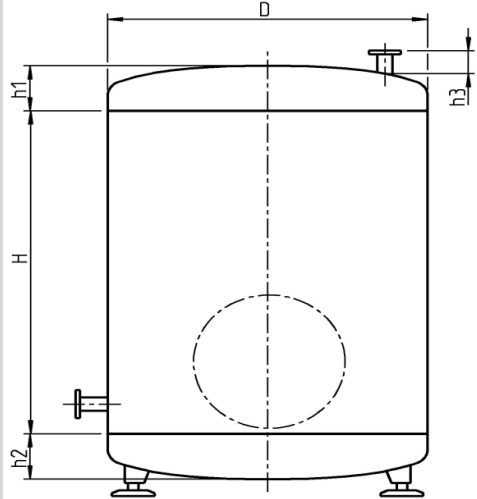
4	<b>Characteristics of tank*</b>	CIP Inlets / Fittings		H (height)	cm		
		Tank	<input type="checkbox"/> vertical <input type="checkbox"/> horizontal	L (length)	cm		
		h1 (cover)	cm	h2 (bottom)	cm	D (diameter)	cm
		h3 (nozzle)	cm	Lateral view draw in the internal fittings and the filling level sowie Füllstandshöhe			
		Topview draw in the nozzles					
		If available please supply detailed tank drawing / sketch to assist with this enquiry					
		requested spray pattern:	internal fittings:	<input type="checkbox"/> Agitators / Mixer <input type="checkbox"/> Scrapers <input type="checkbox"/> Heating Coil <input type="checkbox"/> Baffel <input type="checkbox"/> Measuring instruments <input type="checkbox"/> Other:			
		<input type="checkbox"/> A <input type="checkbox"/> B <input type="checkbox"/> C <input type="checkbox"/> 360° <input type="checkbox"/> 180° <input type="checkbox"/> 180°	Quantity of cleaners:	Use:	<input type="checkbox"/> fixed <input type="checkbox"/> mobile		
			Placing of cleaner:	<input type="checkbox"/> from top <input type="checkbox"/> from bottom			

5	<b>general Information</b> (when available)	Type of contamination*:	<input type="checkbox"/> water-soluble	<input type="checkbox"/> greasy	<input type="checkbox"/> crusted	
			<input type="checkbox"/> solvent-soluble	<input type="checkbox"/> Other:		
		operating pressure	bar	Flow rate	m <sup>3</sup> /h	Material
		Filters for cleaning fluid available:	<input type="checkbox"/> no	<input type="checkbox"/> yes	Micron	
		requested mounting position	<input type="checkbox"/> vertical <input type="checkbox"/> horizontal	<input type="checkbox"/> other:		
		Certificates:	<input type="checkbox"/> FDA <input type="checkbox"/> ATEX	<input type="checkbox"/> Material 3.1		
		monitoring sensor:	<input type="checkbox"/> yes <input type="checkbox"/> no			
favoured function:	<input type="checkbox"/> orbital (3D) <input type="checkbox"/> rotating	<input type="checkbox"/> static				

6	<b>Further comments:</b>	

